

MVAA-260 series

PILOT VALVE



Specification

Model	MVAA-260-4A1	MVAA-260-4A2, 4A2C.P.R	
Bore No.	8A		
Port size	Rc1/4		
No. of port	5		
Medium	Air		
Operating pressure range	0.15~0.8 MPa		
Proof pressure	1 MPa		
Effective orifice	18 mm ²		
Pilot pressure range	(0.3 × P* + 0.1)~0.8 MPa		
Ambient temperature	-5~+60°C (No freezing)		
Weight	153 g	163 g	219 g

※ P: Operating pressure.

Order example

MVAA - 260 - 4A2C - G

MODEL

BODY WIDTH

4: 4way

A1: Single pilot
A2: Double pilot

C: Closed center
P: Pressure center
R: Exhaust center
(Only for 4A2 type)

PORT THREAD
Blank: Rc thread
G: G thread
NPT: NPT thread

Flow features

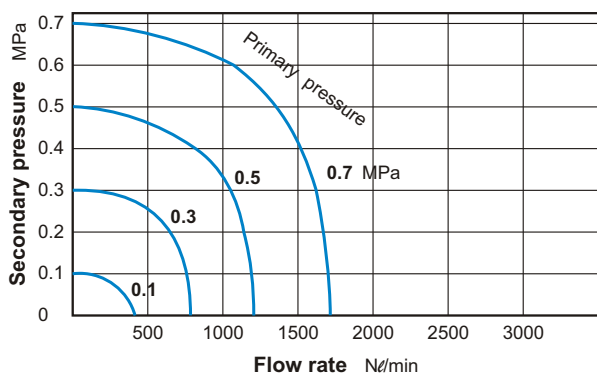

MVAA-260 Dimensions

PILOT VALVE



MVAA-260-4A1

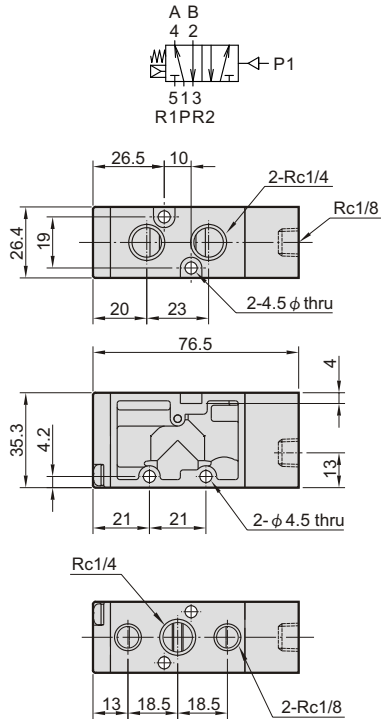

MVAA-260-4A2

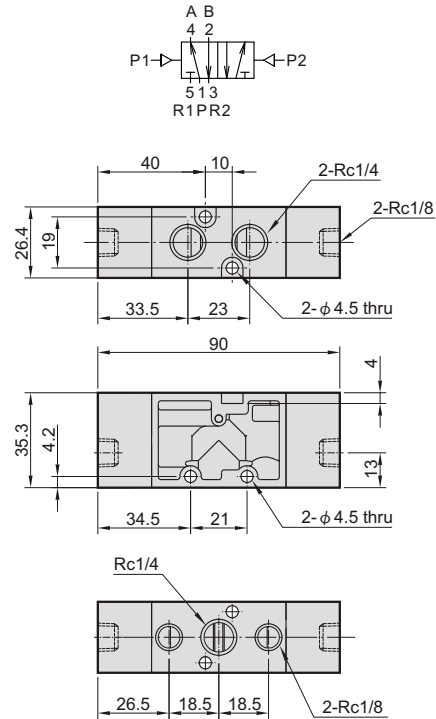

MVAA-260-4A2C.P.R

MVAA-260-4A2C MVAA-260-4A2P MVAA-260-4A2R

